

**Kompakte Verpackungsmaschine, besonders flexibel & vielseitig**  
**Compact packaging machine, extremely flexible and versatile**  
**Machine déballage compact, particulièrement flexible et compacte**



# Kompakte Verpackungsmaschine, besonders flexibel und vielseitig

## Compact packaging machine, extremely flexible and versatile

### Machine d'emballage compacte, particulièrement flexible et compacte

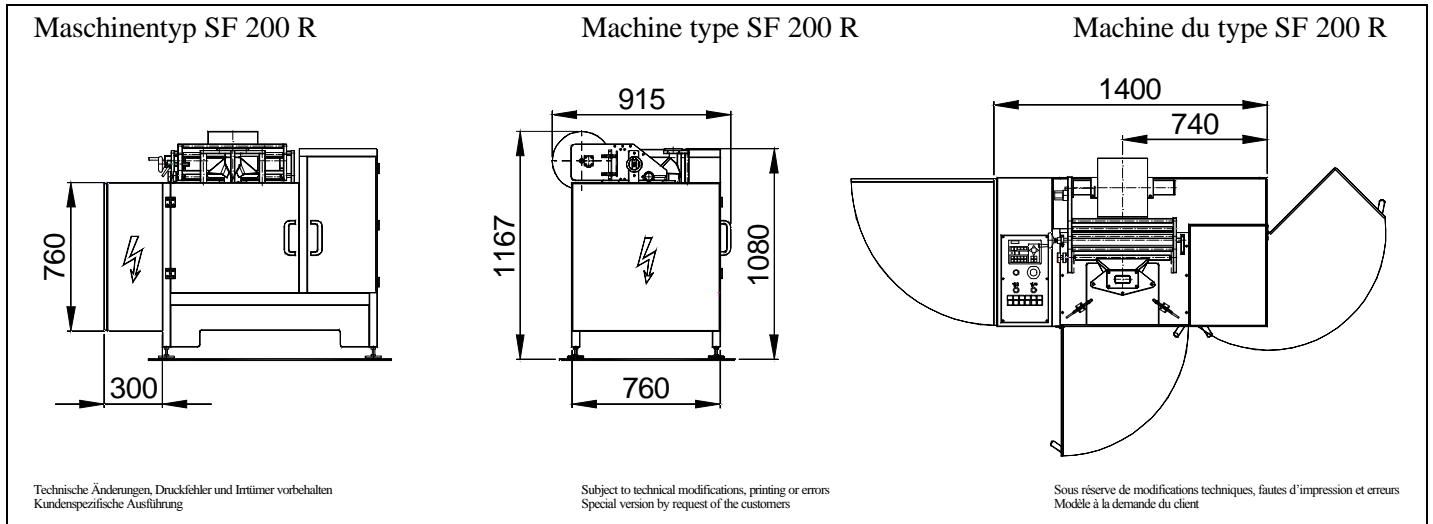

#### TOSS Typ SF 200 R - Technische Daten

- |   |  |
|---|--|
| <ul style="list-style-type: none"> <li>• Beutelbreite: max. 160 mm</li> <li>• Reiterbreite, symmetrisch + asymmetrisch: min. 50 mm / max. 160 mm</li> <li>• Reiterlänge symmetrisch, gefaltet: min. 45 mm / max. 80 mm</li> <li>• Reiterlänge symmetrisch, ungefaltet: min. 90 mm / max. 160 mm</li> <li>• Reiterlänge asymmetrisch, kurzer Schenkel: min. 50 mm / max. 130 mm</li> </ul> | <ul style="list-style-type: none"> <li>• Reiterlänge asymmetrisch, langer Schenkel: max. 205 mm</li> <li>• Reiterlänge asymmetrisch, ungefaltet: max. 335 mm</li> <li>• Leistungsbereich: 15 – 20 Takte/min.</li> <li>• Stromversorgung: 400 V / 50 Hz</li> <li>• Druckluftversorgung: 6 bar, 12 l / Takt</li> <li>• Abmessungen (B x H x T): 1400 x 1100 x 860 mm</li> <li>• Gewicht: ca. 300 kg</li> </ul> |
|---|--|

#### TOSS Type SF 200 R - Technical Data

- |  |   |
|--|---|
| <ul style="list-style-type: none"> <li>• Bag width: max. 160 mm</li> <li>• Header Card width, symmetrical + asymmetrical: min. 50 mm / max. 160 mm</li> <li>• Header Card length, symmetrical, folded: min. 45 mm / max. 80 mm</li> <li>• Header Card length, symmetrical, not folded: min. 90 mm / max. 160 mm</li> <li>• Header Card length, asymmetrical, short side: min. 50 mm / max. 130 mm</li> </ul> | <ul style="list-style-type: none"> <li>• Header Card length, asymmetrical, long side: max. 205 mm</li> <li>• Header Card length, asymmetrical, not folded: max. 335 mm</li> <li>• Machine output: 15 – 20 cycles/min.</li> <li>• Power supply: 400 V / 50 Hz</li> <li>• Compressed air supply: 6 bar, 12 l / cycle</li> <li>• Dimensions (W x H x D): 1400 x 1100 x 860 mm</li> <li>• Weight: approx. 300 kg</li> </ul> |
|--|---|

#### TOSS Type SF 200 R - Caractéristiques techniques

- |  |  |
|--|--|
| <ul style="list-style-type: none"> <li>• Largeur du sachet:</li> <li>• Largeur du cavalier, symétrique et asymétrique: min. 50 mm / max. 160 mm</li> <li>• Longueur du cavalier, symétrique, plié: min. 45 mm / max. 80 mm</li> <li>• Longueur du cavalier, symétrique, non plié: min. 90 mm / max. 160 mm</li> <li>• Longueur du cavalier, asymétrique, côté court: min. 50 mm / max. 130 mm</li> </ul> | <ul style="list-style-type: none"> <li>• Longueur du cavalier, asymétrique, côté long: max. 205 mm</li> <li>• Longueur du cavalier, asymétrique, non plié: max. 335 mm</li> <li>• Cadence de la machine: 15 – 20 sachets/min.</li> <li>• Alimentation électrique: 400 V / 50 Hz</li> <li>• Alimentation pneumatique: 6 bar, 12 l / cycle</li> <li>• Dimensions (largeur x haut. x prof.): 1400 x 1100 x 860 mm</li> <li>• Poids: environ 300 kg</li> </ul> |
|--|--|